

ACQUISITION SYSTEM FOR TEMPERATURE MONITORING AND CONTROL IN SIX MEASUREMENT POINTS MADE USING PIC16F877A MICROCONTROLLER

Antonie Nicolae¹, Borcosi Ilie², Cozma Vasile³

¹ "Constantin Brâncuși" University from Târgu Jiu

² "Constantin Brâncuși" University from Târgu Jiu

³ "Constantin Brâncuși" University from Târgu Jiu

ABSTRACT. In industrial applications and beyond, temperature measurement is one of the most common situations. In this paper we present the development of a data acquisition system for temperature monitoring and control in two chambers, a system built around a core type PIC16F877A microcontroller.

СИСТЕМА ЗА МОНИТОРИНГ НА ТЕМПЕРАТУРАТА И КОНТРОЛ В ШЕСТ ИЗМЕРВАТЕЛНИ ПУНКТА, ОСЪЩЕСТВЕНА С МИКРОКОНТРОЛЕР PIC16F877A

Антони Николае¹, Боркози Илие², Козма Василе³

¹ "Университет „Константин Бранкузи“ от Търгу Жиу

² "Университет „Константин Бранкузи“ от Търгу Жиу

³ "Университет „Константин Бранкузи“ от Търгу Жиу

РЕЗЮМЕ. Измерването на температурата е една от най-често срещаните ситуации в индустрията и на други места. В този доклад се представя разработването на система за събиране на данни за мониторинг и контрол на температурата в две камери, система изградена около микроконтролер с ядро тип PIC16F877A.

The description of development PIC16F877A

The PIC16F877A Microcontroller is part of the 8-bit PIC microcontrollers family, has a complex internal structure, is able to acquire analog signals having constituted an analog-digital 10-bit, can generate PWM signals, can communicate with external devices lends itself particularly well in industrial applications.

It presents five bidirectional ports configurable for use by installation and can be used in very complex applications.

In this paper we propose creation of a data acquisition system for temperature monitoring and control in six chambers.

The block diagram used for temperature monitoring is shown in the figure 1.

The LM35 temperature sensor is part of integrated sensors and measurement range is between -55 and 150 degrees Celsius.

The analog signals taken from the temperature sensors LM 35 type are applied to two of the microcontroller analog inputs which are converted via an analogue incorporated digital converter.

All these signals are processed by the microcontroller through the program written in his memory.

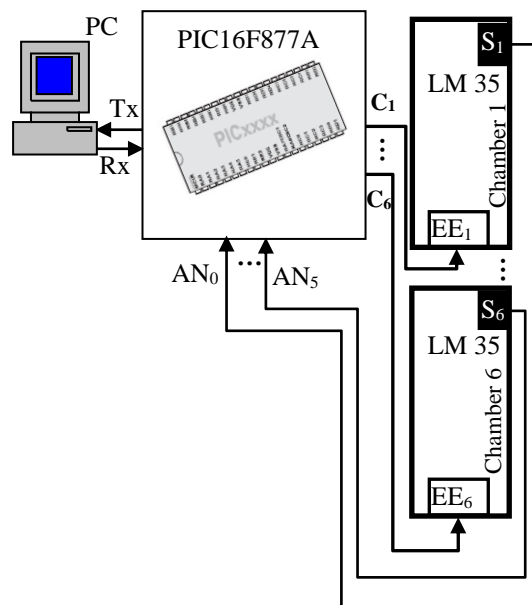

Fig. 1. The block diagram used for temperature monitoring

The processed data are submitted by the serial to a computer that running a software purchase which serves to display signals in graphical form and the human operator using an interface can view the processed data and can intervene by setting certain parameters for alarm, etc.

The proposed acquisition system can be extended to other applications by adapting the signals to the system requirements, by modifying the program written in program memory of the microcontroller to the new arrangement and operator interface running on the computer.

The serial module transmission of the data between the microcontroller and the computer circuit is provided with optocouplers for galvanic isolation so that a fault can occur in the purchasing system will not cause damage to computer systems and vice versa.

The electronic signal acquisition diagram used is shown in the figure 2.

The LM35 temperature sensor is part of integrated sensors and measurement range is between -55 and 150 degrees Celsius.

Integrated transducers for measuring temperature are first integrated transducers occurred. Although their measurement range is not too large (- 50, 1500 C), they are a number of applications from measuring ambient temperature, but also to measure other quantities through temperature variations from these quantities.

Are widespread two types of integrated sensors for temperature measurement:

- Output current transducer that varies in direct proportion to absolute temperature;
- Sensors that output voltage varies in direct proportion to absolute temperature.

For the first category is representative AD590 circuit (Analog Devices product - U.S.).

In the second category presents the integrated circuit LM 35 (National Semiconductor - USA).

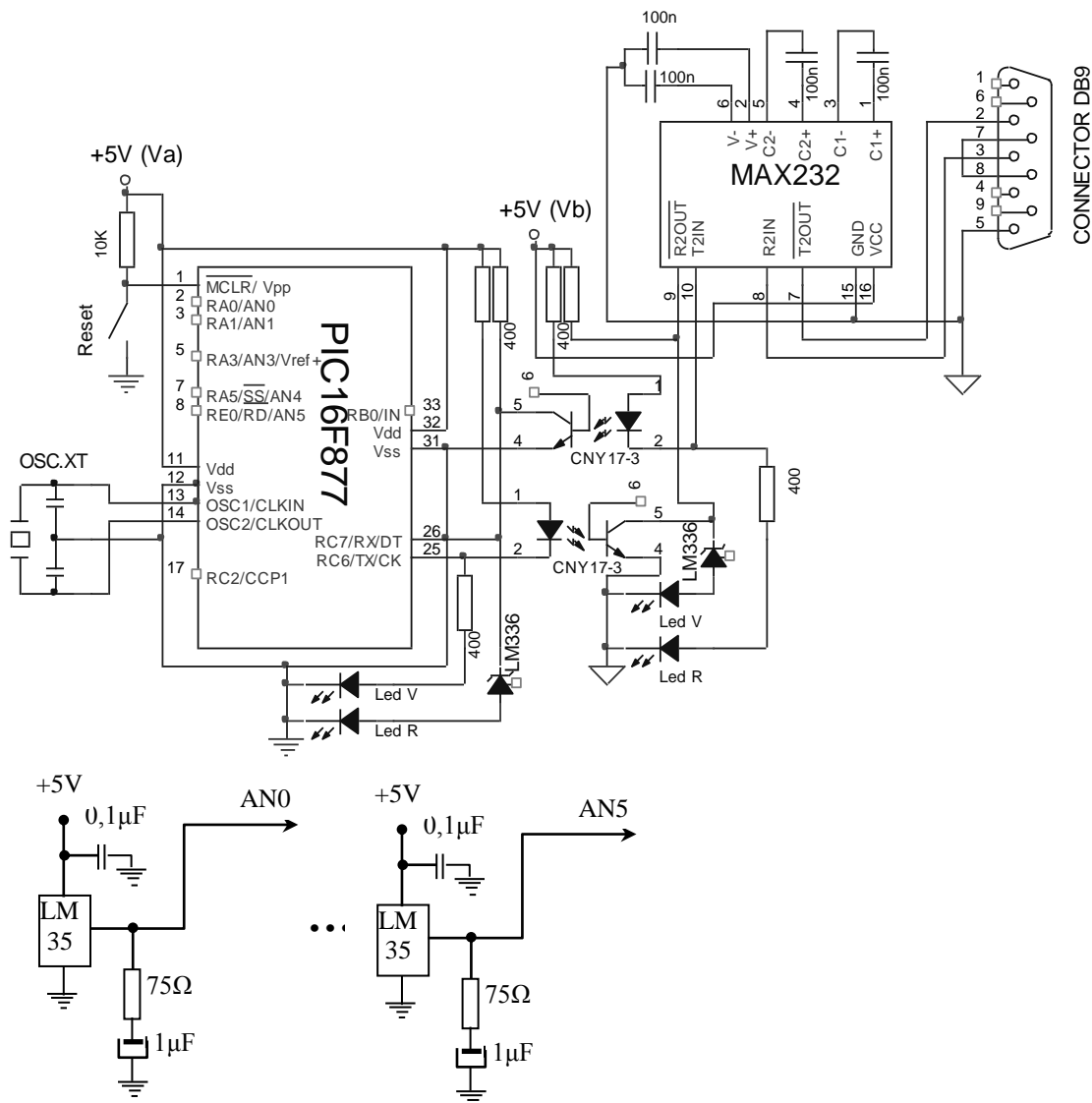

Fig. 2. The electronic signal acquisition diagram

The analog signals taken from the temperature sensors LM 35 type are applied to two of the microcontroller analog inputs

which are converted via an analogue incorporated digital converter.

All these signals are processed by the microcontroller through the program written in his memory.

The processed data are submitted by the serial to a computer that running a software purchase which serves to display signals in graphical form and the human operator using an interface can view the processed data and can intervene by setting certain parameters for alarm, etc.

The proposed acquisition system can be extended to other applications by adapting the signals to the system requirements, by modifying the program written in program memory of the microcontroller to the new arrangement and operator interface running on the computer.

The serial module transmission of the data between the microcontroller and the computer circuit is provided with optocouplers for galvanic isolation so that a fault can occur in the purchasing system will not cause damage to computer systems and vice versa.

Tacking changes in temperature in the six chambers was achieved by using a virtual instrument with the programming environment LabWindows / CVI.

In figure 3 is shown the front panel control and visualization and it represents the interface between the purchasing system and human operator.



Fig. 3. The front panel control interface

The human operator can set via the interface certain temperature ranges represent the limits within which it wishes to maintain the temperature in each chamber.

The temperature control can mean, for example, design a control system working on a follow-up. The control system aims the temperature at a chamber and trying to maintain constant temperature in the second chamber. This system can be used to control an installation that introduces fresh air ventilation in a room. The control is achieved by modifying the reference to compensation for summer and winter to maintain the temperature difference between inside and outside to a level as low as possible.

Conclusions

The complexity of developing such a system does not stop here, it may be extended depending on the requirements and complexity of technological devices that must be managed. By simply removal in the external using connector of the microcontroller port, we can expand the applications that can be achieved through the platform and the possibilities, and not only, of serial communication such microcontrollers with a process computer or other such devices to be increasingly used in complex industrial applications, etc.

An important advantage of the application submitted is the discounted price of made and flexibility.

References

- Antonie, N., Borcoși, I., Dincă, A., Ionescu, M., *FOC Control System of AC Machines*, Analele Universitatii „Constantin Brancusi” din Tg. Jiu, Seria Inginerie, no.2/2008, ISSN 1844 – 4856, pag. 307-312.
- Antonie, N., Borcoși, I., Ionescu, M., Acquisition and development system with PIC16F84 and PIC16F877 microcontrollers, Analele Universitatii „Constantin Brancusi” din Tg. Jiu, Seria Inginerie, no.3/2010, ISSN 1842 – 4856, pag. 293-301.
- Borcosi I., Onisifor O., Popescu M.C., Antonie N., "A Method to Protect from no Pulse for a Three-Phase Rectifier Bridge Connected with the Resistive-Inductive Load", Proceedings of the 10th WSEAS International Conference on Mathematical and Computational Methods in Science and Engineering, Bucharest, November 2008, pp.146-152.
- Borcosi I, Olaru O, Popescu M.C., Antonie N., "Method to Protect from no Pulse for a Three-Phase Rectifier Bridge", International Journal of Mathematical Models and Methods in Applied Sciences, January 2009, pp.473-482.
- Borcoși Ilie, Olaru Onisifor, Popescu Marius-Constantin, Dincă Alina, Device with Analogical Circuits for Protection to the Lack of the Pulse for the Three-Phase Rectifiers in Bridge, Proceedings of the 10th WSEAS International Conference on MATHEMATICAL and COMPUTATIONAL METHODS in SCIENCE and ENGINEERING (MACMESE '08), Bucharest, Romania, Nov. 7-9, 2008, Part I, ISSN: 1790-2769, ISBN:978-960-474-019-2, pp. 152-157.
- Borcoși Ilie, Olaru Onisifor, Popescu Marius-Constantin, Dinca Alina, Antonie Nicolae, Ionescu Marian, Device with Analogical Circuits for Protection to the Lack of the Pulse for the Three-Phase Rectifiers in Electrical Drive, INTERNATIONAL JOURNAL OF MATHEMATICAL MODELS AND METHODS IN APPLIED SCIENCES, Issue 4, Volume 2, December 2008, ISSN: 1998-0140, pp. 483-492.
- Ilie Borcoși, Onisifor Olaru, Nicolae Antonie, Device for Protection to the Lack of the Pulse for the Tri-Phase Rectifiers in Bridge, International Journal of Computers, Communications & Control, ISSN 1841-9836, E-ISSN 1841-9844, Vol. III, 2008, pp. 196-200.
- Marius-Constantin Popescu , Ilie Borcoși, Onisifor Olaru, Luminița Popescu, Florin Grofu, Simulation Hybrid Fuzzzz Control of SCARA Robot, 2007, Proceedings of the 3rd WSEAS International Conference on Applied and THEORETICAL MECHANICS (Mechanics '07), Tenerife, Spain, December 14-16, 2007, pag. 175-180 Published by WSEAS Press, ISBN: 978-960-6766-19-0, ISSN: 1790-2769;
- Marius-Constantin Popescu , Ilie Borcoși, Onisifor Olaru, Luminița Popescu, Florin Grofu, The Simulation Hybrid Fuzzy Control of Scara Robot, WSEAS TRANSACTIONS ON SYSTEMS AND CONTROL, Issue 2, Volume 3, February 2008, ISSN: 1991-8763.
- Popescu M.C., Mastorakis N., Borcosi I., Popescu L., Asynchronous Motors Drive Systems Command with Digital Signal Processor, International Journal of Systems Applications, Engineering & Development, Issue 2, Vol.3, pp.64-73, 2009.
- Paturca, S., V., Covrig, M., Cepisca, C., Serita, G., Proposed Schemes for Improving the Steady State Behaviour of Direct Torque Controlled Induction Motor, Proceedings of the 7th WSEAS International Conference on Power Systems, Beijing, China, September 15-17, 2007, pp. 53-58.
- Borcoși, I., Dincă, A., Nebunu, D.L., Antonie N., A., High performance digital control system of AC Machines, Annual of University of Mining and Geology „St. Ivan Rilski” – Sofia, vol. 51, Part III, Mechanization, electrification and automation in mines, 2008, ISSN 1312-1820, pp. 23-26.
- PIC 16F877 Datasheet 28/40-Pin CMOS FLASH Microcontrollers.
- LM35/LM35A Datasheet, Precision Centigrade Temperature Sensors.
- Nenova Z. P., Velev G. Ts., Measurements and control in the occupational safety engineering, “Gabrovo Print”-EOD, 2008, ISBN: 978-954-436-024-5