

## IDENTIFICATION OF EXPOSED ROCKS IN OPEN PIT MINES USING INFRARED SPECTRAL DATA

*Denitsa Borisova<sup>1</sup>, Banush Banushev<sup>2</sup>, Hristo Nikolov<sup>1</sup>, Doyno Petkov<sup>1</sup>*

<sup>1</sup>Space Research and Technology Institute, Bulgarian Academy of Sciences /SRTI-BAS/, 1113 Sofia; dborisova@stil.bas.bg

<sup>2</sup>University of Mining and Geology "St. Ivan Rilski", 1700 Sofia; banushev@mgu.bg

**ABSTRACT.** In this study satellite data from Advanced Spaceborne Thermal Emission and Reflection Radiometer (ASTER) in the wavelength range (1.6-2.5  $\mu\text{m}$ ) of bare rocks and soils in the region of open pit mines "Elshitsa" and "Tsar Asen" in Bulgaria were used. The spectral reflectance of exposed rocks was compared with the spectral reflectance of the same rocks taken from different spectral libraries. The analysis of the spectral characteristics in the specified range indicates maintain their specific features. In the obtained curves were observed distinctive extrema that be able to be used to identify the type of rocks. The results show that the suggested methods for analyzing the spectral data could be used to identify exposed rocks. Theoretical and analytical techniques that have been developed for the analysis of the laboratory spectral data also could be applied to field spectral data.

### ИДЕНТИФИКАЦИЯ НА СКАЛИ В ОТКРИТИ МИНИ ПО ИНФРАЧЕРВЕНИ СПЕКТРАЛНИ ДАННИ

*Деница Борисова<sup>1</sup>, Бануш Банушев<sup>2</sup>, Христо Николов<sup>1</sup>, Дойно Петков<sup>1</sup>*

<sup>1</sup>Институт за космически изследвания и технологии, Българска академия на науките, 1113 София; dborisova@stil.bas.bg

<sup>2</sup>Минно-геоложки университет "Св. Иван Рилски", 1700 София; banushev@mgu.bg

**РЕЗЮМЕ.** В настоящата работа са използвани спътникови данни от инструмента ASTER в каналите в спектралния диапазон (1.6-2.5  $\mu\text{m}$ ) за открити скали и почви в района на мините „Елшица“ и „Цар Асен“ в България. Спектралната отражателна способност на скалите е сравнена със спектралната отражателна способност на същите скали, взета от различни спектрални библиотеки. Анализът на получените спектрални характеристики в посочения диапазон показва запазване на техните специфични особености. На получените графики се наблюдават характерни екстремуми, които могат да бъдат използвани за идентифициране на вида на скалите. Резултатите показват, че предложените методи за анализ на спектралните данни могат да се използват за идентифициране на скални разкрития. Методите, които са разработени за анализ на спектралните лабораторни данни могат да бъдат приложени и за полеви спектрални данни.

## Introduction

Surface mining activities in Europe are estimated to cover a large area and range from large open-cast coal and base metal mines, to much smaller aggregate, industrial minerals, and building materials quarries. Remote sensing a useful method to monitor open pit mines in different scales. In this study satellite data from ASTER instrument channels in the wavelength range (1.6-2.5  $\mu\text{m}$ ) of exposed rocks in the region of abandoned open pit mines "Elshitsa" and "Tsar Asen" in Bulgaria were used. The spectral reflectance of exposed rocks was compared with the reference spectral reflectance of the same rocks taken from different spectral libraries (ASTER, USGS and JPL). The analysis of the spectra in the specified range indicates maintain their specific features. In the obtained curves were observed distinctive extrema that be able to be used to identify the type of rocks. The results show that the suggested methods for analyzing the spectral data could be used to identify exposed rocks. Theoretical and analytical techniques that have been developed for the analysis of the laboratory spectral data also could be applied to the field spectral data.

## Materials and Methods

### ASTER Instrument

The Advanced Spaceborne Thermal Emission and Reflection Radiometer (ASTER) is an imaging instrument onboard Terra, the satellite of NASA's Earth Observing System (EOS) launched in December 1999. ASTER is a cooperative effort between NASA, Japan's Ministry of Economy, Trade and Industry (METI), and Japan Space Systems (J-spacesystems). ASTER data is used to create detailed maps of land surface temperature, reflectance, and elevation. The coordinated system of EOS satellites, including Terra, is a major component of NASA's Science Mission Directorate and the Earth Science Division. The goal of NASA Earth Science is to develop a scientific understanding of the Earth as an integrated system, its response to change, and to better predict variability and trends in climate, weather, and natural hazards (<http://asterweb.jpl.nasa.gov/index.asp>, June 2016).

The ASTER instrument consists of three separate instrument subsystems. Each subsystem operates in a different spectral region, has its own telescope(s), and was built by a different Japanese company.

ASTER's three subsystems are: the Visible and Near Infrared (VNIR), the Shortwave Infrared (SWIR), and the Thermal Infrared (TIR). In our study were used data from subsystem in SWIR region.

### ASTER Instrument Subsystem SWIR

The SWIR subsystem (fig. 1) operates in six spectral bands in the near-IR region through a single, nadir-pointing telescope that provides 30 m resolution. Cross-track pointing ( $\pm 8.550$ ) is accomplished by a pointing mirror. Because of the size of the detector/filter combination, the detectors must be widely spaced, causing a parallax error of about 0.5 pixels per 900 m of elevation. This error is correctable if elevation data, such as a DEM, are available. Two on-board halogen lamps are used for calibration in a manner similar to that used for the VNIR subsystem, however, the pointing mirror must turn to see the calibration source. The maximum data rate is 23 Mbps (<http://asterweb.jpl.nasa.gov/instrument.asp>, June 2016).

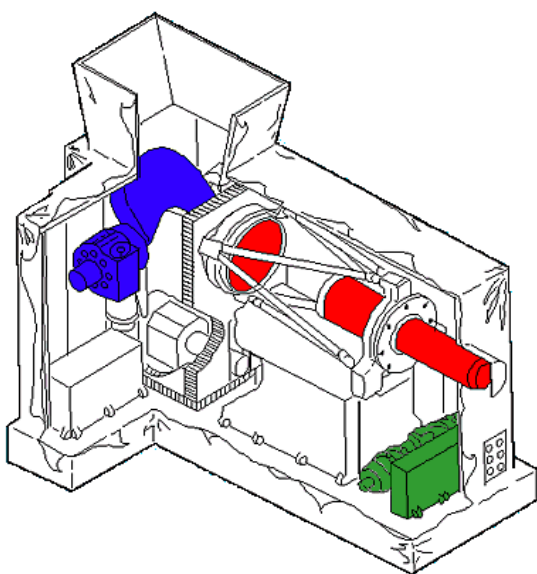

Fig. 1. ASTER Instrument Subsystem SWIR (<http://asterweb.jpl.nasa.gov/swir.asp>, June 2016)

### ASTER Instrument Characteristics

The main characteristics of ASTER instrument are presented in Table 1 (<http://asterweb.jpl.nasa.gov/characteristics.asp>, June 2016).

Table 1.  
ASTER Instrument Characteristics

No	Characteristic	SWIR
Ch1	Spectral Range	Band 4: 1.600 - 1.700 $\mu\text{m}$
Ch2		Band 5: 2.145 - 2.185 $\mu\text{m}$
Ch3		Band 6: 2.185 - 2.225 $\mu\text{m}$
Ch4		Band 7: 2.235 - 2.285 $\mu\text{m}$
Ch5		Band 8: 2.295 - 2.365 $\mu\text{m}$
Ch6		Band 9: 2.360 - 2.430 $\mu\text{m}$
	Ground Resolution	30 m
	Data Rate (Mbits/sec)	23

The ASTER bands are superimposed on model atmosphere presented on Figure 2.

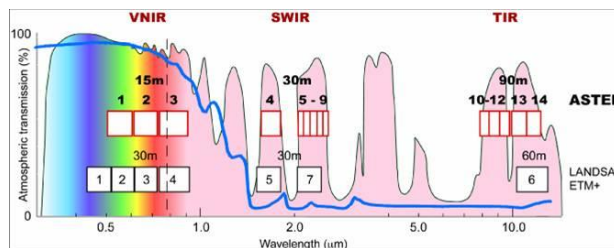

Fig. 2. ASTER bands (<http://asterweb.jpl.nasa.gov/images/spectrum.jpg>, June 2016)

### ASTER Spectral Library

The ASTER spectral library includes data from three other spectral libraries: the Johns Hopkins University (JHU) Spectral Library, the Jet Propulsion Laboratory (JPL) Spectral Library, and the United States Geological Survey (USGS - Reston) Spectral Library.

In the present study we used data from the ASTER spectral library for comparing the obtained infrared spectral data from ASTER instrument onboard of the airborne platform and the same data from laboratory measurements for the same rock samples included in the spectral libraries (Baldrige et al., 2009).

### Region of Interest (RoI)

In the present study the RoI is the Panagyurishte ore region. The Panagyurishte ore region (fig. 3) is located in the Central Sredna Gora and partly in the Stara Planina mountains in Bulgaria.

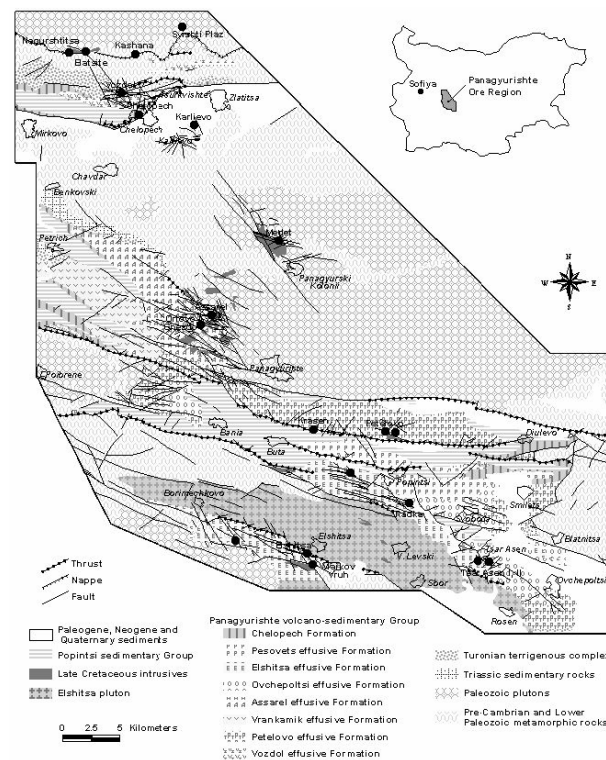

Fig. 3. Geological map of the Panagyurishte ore region (Popov, 2005)

The Upper Cretaceous Elshitsa volcano-intrusive complex comprises the rocks of Elshitsa stratovolcano, the Elshitsa pluton as well as numerous subvolcanic and subvolcanic-hypabyssal minor intrusives and dikes. The ore district is a

stripe-like area of East-South-East direction, about 20 km long and 4 km wide in the northern slope of the Elshitsa stratovolcano. The Elshitsa pluton is exposed along the southern border as a result of fault uplift of the central block of the volcano (Попов, 2002).

Our study is focused on abandoned open pit mine “Elshitsa” and Elshitsa pluton. This pluton is formed by granite, granodiorite and their porphyritic varieties (Lilov and Chipchakova, 1999).

## Results and Discussion

### Reference spectra

Reference spectra of granites were obtained from the USGS and JPL spectral libraries (Clark et al., 2007). The USGS spectral library contains reference spectra for rocks and soils that represent different localities around the world but most of them are presented in one particle size (Clark et al., 2007).

### Spectral analysis

According specific features of the spectral curves the USGS and JPL reference spectra of granite were analyzed. The infrared spectra of granite have increased water vapor, which causes a noticeable sawtooth appearance in the short wavelength region of the spectra (2–3  $\mu\text{m}$ ).

Results show that it has an absorption feature around 1.9,  $\mu\text{m}$  (fig. 4). The 1.9  $\mu\text{m}$  feature is obscured by atmospheric (water) absorption (Curran et al., 2001). This minimum in the spectral characteristics can be found in laboratory spectral data because of the more energy reaching the instrument detector.

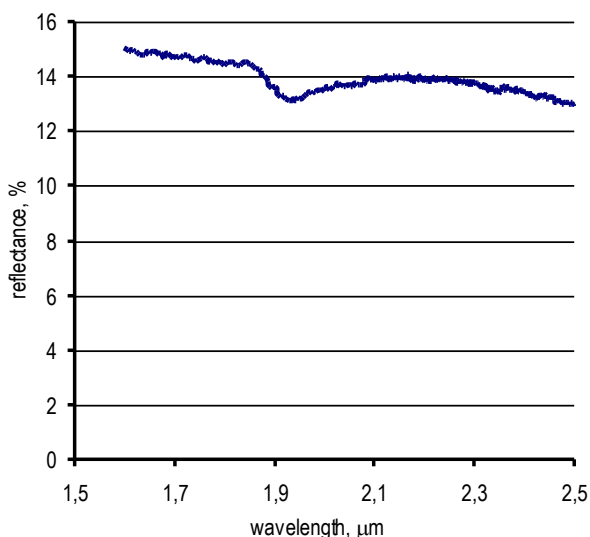

Fig. 4. Plot showing ASTER spectra of granite (Baldrige et al., 2009)

The ASTER spectra of exposed granites in “Elshitsa” open pit mine (green line in Fig. 5) have the same trend as reference spectra from the spectral library. The missing spectral data because there are no detectors in the spectral range (1.8-2.1  $\mu\text{m}$ ) could be cause for misinterpretation of the infrared spectral data. Therefore additional laboratory and field

spectrometric measurements in this spectral range have to be planned and performed.

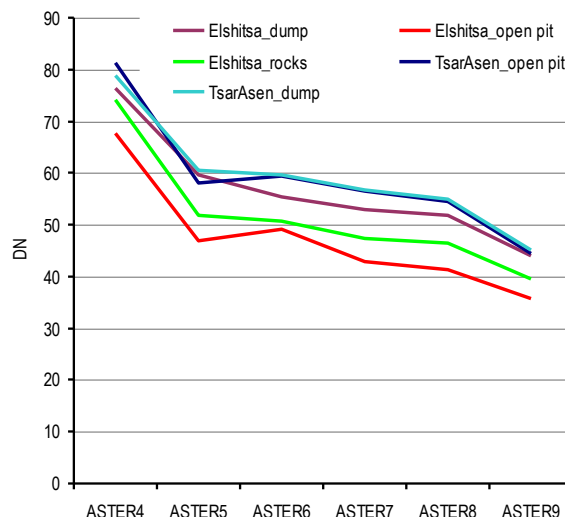

Fig. 5. Plot showing ASTER spectra of open pit mines “Elshitsa” and “Tsar Asen”, their dumps and exposed rocks.

In Table 2 the statistics for used in the study data is shown.

Table 2.

*Histogram summary table for ASTER data in Rol*

No	Data Range	Mean	Median	St. Dev.
Ch1	0-255	38.5	51	36.2
Ch2	0-255	27.9	34	27.8
Ch3	0-255	29.6	34	30.0
Ch4	0-255	26.3	30	27.1
Ch5	0-255	25.8	28	27.4
Ch6	0-255	22.4	26	23.3

## Conclusions

In this study were used multispectral data of the Advanced Spaceborne Thermal Emission and Reflection Radiometer (ASTER) data to identify exposed rocks in the “Elshitsa” and “Tsar Asen” open pit mines in Bulgaria. The results show that the suggested methods for analyzing the spectral data could be useful to identify exposed rocks. Theoretical and analytical techniques that have been developed for the analysis of the laboratory spectral data also could be applied to field spectral data. For future work, this study suggests that collecting field reflectance spectra of the different exposed rocks and laboratory spectral measurements of the field samples. The collected spectra could be used for ASTER image classification and compare the results with the reference spectra of the USGS and JPL spectral libraries.

## References

Попов, К. Геохимични асоциации в Радкинското рудно поле. – Год. на Минно-геология университет “Св. Иван Рилски”, 45, Св. I: Геология и геофизика, 2002. – 55-62.

Baldrige, A. M., S.J. Hook, C.I. Grove and G. Rivera. The ASTER Spectral Library Version 2.0. – *Remote Sensing of Environment*, 113, 2009. – 711-715.

Clark, R.N., G.A. Swayze, R. Wise, E. Livo, T. Hoefen, R. Kokaly, S.J. Sutley. USGS digital spectral library splib06a: U.S. Geological Survey. *Digit. Data Ser. 231*, 2007.

Curran, P.J., J.L. Dungan, D.L. Peterson. Estimating the foliar biochemical concentration of leaves with reflectance spectrometry testing the Kokaly and Clark methodologies. - *Remote Sens. Environ.* 76, 2001. – 349-359.

Lilov, P., S. Chipchakova. K-Ar dating of the Upper Cretaceous magmatic rocks and hydrothermal metasomatic rocks from the Central Srednogie. – *Geochem., Mineral. and Petrol.*, 36, 1999. – 77-91.

Popov, K. Lithostratigraphy of the Late Cretaceous rocks in the Panagyurishte ore region. - *Annual of the University of Mining and Geology "St. Ivan Rilski"*, 48, Part I: *Geology and Geophysics*, 2005. – 101-114.

<http://asterweb.jpl.nasa.gov/characteristics.asp>

<http://asterweb.jpl.nasa.gov/images/spectrum.jpg>

<http://asterweb.jpl.nasa.gov/index.asp>

<http://asterweb.jpl.nasa.gov/instrument.asp>

<http://asterweb.jpl.nasa.gov/swir.asp>

The article is reviewed by Assist. Prof. Dr. Christian Tzankov and recommended for publication by the Department „Applied Geophysics“.