

SAMPLING DEVICE ADAPTABLE TO THE HIGH CAPACITY CONVEYER - BELTS

Nicolae Cristea

University of Petrosani
Petrosani 2675
Romania

Gheorghe Gherman

University Aurel Vlaicu
Arad, 2900
Romania

Georgeta Cristea

University of Petrosani
Petrosani 2675
Romania

ABSTRACT

In our country, the manual sampling is the usual manner at the sub-bituminous coal furnishing to beneficiaries although this one is affected by human errors, is expensive and is not recommended by International Standards. Because the mechanical sampling endeavors failed in the conditions of big discharges of the belt conveyers in the loading points, the manual sampling is still applied. The paper analyses the various feasible procedures for sampling, with their benefits and also drawbacks. The most difficult problems are those in connection with: the device utilization in the available space in the loading points, the high material flows, the upper size of the material. The proposed solution respects the specific requirements of International Standards about mechanical sampling. The device fastening will be realized on the belt frame, thus ensuring its placement in existing space. The constitutive elements of this ensemble are: the deflector shield, the sampling device and the taking over device. Each of these elements has a fixed role for safe working conditions of the device.

INTRODUCTION

In the current tendency of all activities harmonization with the communitarian AQ, the sub-bituminous coal furnishing from quarries to customers required a close examination concerning the safeguard of a suitable accuracy in coal sampling. The present coal loading point structure does not refer of mechanical sampling and its equipping with mechanical sampling device is impossible, for that time the manual methods of coal sampling were thought to be corresponding.

Frequently, in the long run, the manual methods of coal sampling were a disputed subject between producer and customers and a narrow place with drawbacks like:

- the manual method of coal sampling from train loads requires a lot of labour;
- the staff subjectivity determines a lot of controversies;
- the necessary time for manual sampling can determine punishment for the vehicle stopping from the transport company;
- there is outsized staffs in this activity.

All this outstanding issues in the circumstance of big moving steams and of the material granulometry don't recommend the manual methods of coal sampling.

CASE ANALYSIS

The sub-bituminous coal analysis had in view to establish the granulometric composition, the moisture content and the minimum flowing angle for extreme conditions. Although the granulometric analysis indicated lump size higher 150mm value, we considered that this situation rose because of the shortcomings in coal preparation for delivery and the situation must be remedied.

Usually, the sub-bituminous coal granulometry is like that witch is presented in figure 1.

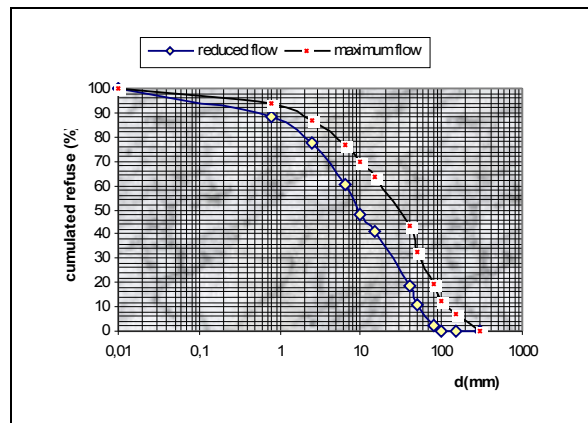

Figure 1. Granulometric limits of the delivered sub-bituminous coal

The flowing angle for coal, in extreme condition, on metallic surface, using special sample from different sectors and of different moisture contents was established at a value of 25°. The material speed in discharge point from the belt, in the impact point with deflector shield is of 6 – 7m/s. The maximum flow value on belt conveyer that feeds the loading point is 500kg/s.

The replace of manual methods of coal sampling from road or rail vehicle charges with mechanical sampling from steams moving on the high speed belt conveyers determined the subsequent problems:

- in the case of using a scrapping device for coal sampling:

- the repeatable stopping of the loading belt generates higher power requirement and premature wear of the belt driving system;
- the belt stops can generate shutting off in previous loading flux;
- there is a dangerous operation for belt safety to use a device that can totally take over the material from the belt; any lump that interposes between the device wall and the belt of high speed can produce the belt deterioration.
- in the case of using a sampling device with bucket that traverses the downward coal stream:
 - the bucket size has to be large because of coal granulometry and its high downward flow and also, the standard recommends that the maximum bucket load at a single passing through the coal flow has to be no more $\frac{3}{4}$ from its volume;
 - this large buckets are inadequate in the actual sampling point;
 - in the dynamic regime, the bucket and its driving device must be mechanical oversized, thus being able to assume the whole dynamic charge of material flow of 6 – 7m/s speed value.

The mechanical sampling of the incremental sample has to be able to produce representative samples. In this sampling method, the representative coal samples are in higher quantities and therefore had to follow a mechanical preparation in order to obtain the laboratory sample. The mechanical preparation device must include a mass division stage and also a stage for the decreasing in maximum lump size. The mechanical preparation device must assure a continuously and proportionally of the reduced sample taking over and also a continuously preparation in order to avoid the introduction of a homogenisation operation.

SOLUTION IDENTIFICATION

In order to establish the alternative that will be applied in the concrete conditions, six basic alternatives with their advantages and disadvantages were analysed. The selected alternative has to bring together a general feasible solution and a maximum accuracy in the representative sample constitution. The sampling device can be assembled on the belt frame in the material discharge moment at the loading point and has to comply with all standard requirements concerning the representative sample constitution.

From the point of view of the constructive nature, the installation has to have:

- a device capable to assume the dynamic energy of the material that is projected from the belt and to conduct it towards the sampling device
- a device for the increment sampling capable to traverse the entire falling flow and to conduct this material to the preparation device

- a suitable tightness able to eliminate the deliberate or casual contamination of the representative sample.

INSTALLATION DESCRIPTION

In order to ensure all these requirements, the mechanical sampling installation was conceived of three solid connected sub-assemblies, presented in figure 2:

- the deflector shield, A
- the proper device for sampling, a chute, with its driving system, B
- the taking over device for increments, C

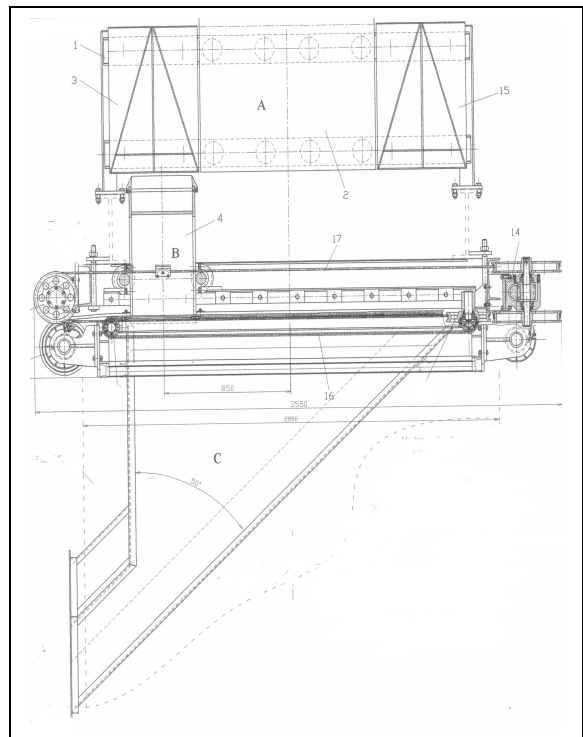

Figure 2. Sampling installation (side view)

The installation will be placed where the actual belt deflector screen is.

The deflector shield, A, is thus conceived that to be stiffened on the belt conveyer frame through the stiffening frame (1). The screen (2) of the deflector shield is attached of the stiffening frame through elastic systems. The screen is made out of rubberised metallic material, which will assure the minimizing of the impact between the material and the shield and will deflect it towards the sampling device, B, through the smallest possible area.

The proper device for sampling is in such way built that the sampling will be achieved through the material deviation from the influence zone of the drawing bucket.

The chute (4) that realizes the increment sampling traversing the entire falling flow has the following constructive specific features:

- chute width: 400mm;

- the collected and loading flow ratio, during the active runs is 1:3;
- the chute length is dictated by the material scattering zone after the impact with the deflector shield;
- the chute's side walls are equipped on the top side with cutters which protect against wear;
- the inclination angle of the device's base: 30°;
- the cutting speed of the material flow is about 12m/s and can be regulated through the driving device;
- during the crossing through material flow, the chute speed must be invariable. In this way, the proportionality principle between the quantities of charged material in chute and the transported material flow in that section is respected;
- in the representative sample constitution, the incremental mass is proportional with the material flow in the sampling moment.

In the conditions of maximum flow value, the loading time of a lot corresponding to 2400t is of 80 minutes.

If the valid standards are respected, the representative sample has to include 32 incremental sample, namely at each 150 seconds, an incremental sample must be gathered and the representative sample weight will be of 5 tonnes.

From the constructive point of view, the chute is supported through four elastic couplings from two roll axes, which slides on the supporting frame. Through the driving group, the device performs a translation movement that allows the increment sampling. The system is a carcasses building and is endowed with an auto-cleaning device for rolling way. Towards the discharge zone, the chute is tight fixed through some straps with the rubberier carpet. Thus, the collecting chute moves concomitantly with the carpet wind and rewind. At each end, the collecting chute retires under two directional screens (15), where remains during the stationed period and thus the avoidance of the particle penetration are ensured. The selected solution requires the chute sizing only like a passing device and not like an accumulating one and the taking over angle reduces the impact charge.

The incremental sample taking over device, C, consists of tight carpet and the sample taking over chute. The tight carpet moves concomitantly with the collecting chute because the same device drives them. It is maintained stretched through the two rolling cylinders (11) that are endowed with pretension spiral springs.

The belt is crosswise stiffened with metallic bands against the chain with rolls (16) and thus ensures the perfect tightness of the upper part of the taking over chute.

The taking over chute connects the chute with a sample bin or with a conveyor device that feeds the bin. There is a drive cable (17) that transmits the motion from the driving to the hydraulic (14) devices, to the collecting chute, to the tight belt and to the chain with rolls.

In order to remove the shocks that appear when the chute is starting or stopping, it is equipped with damping springs. The dynamics scheme of the installation is presented in figure 3.

Sampling interval, the interval between taking increments shall be regulated by needs, using a time relay, which acts when equal loads are achieved.

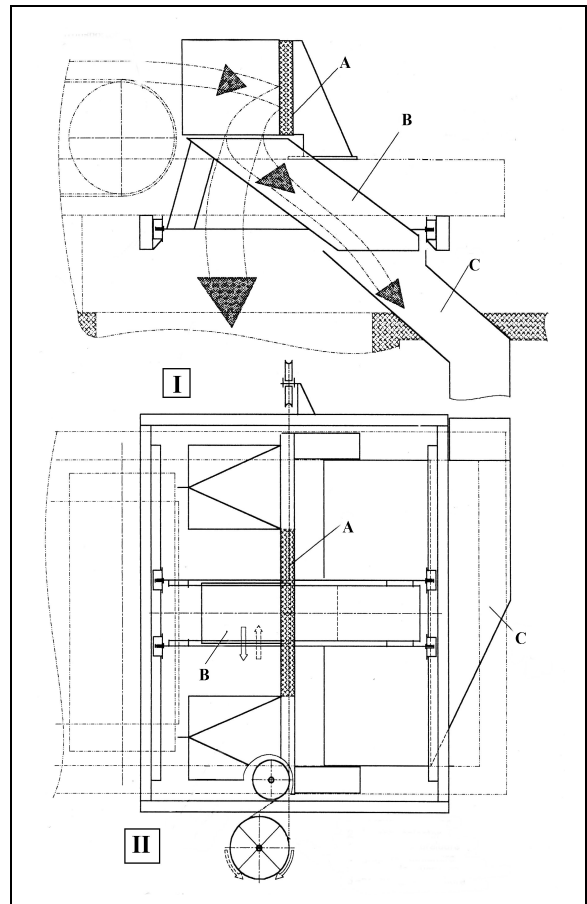

Figure 3. (I) The material and sampling trajectory. (II) Diagram and the sampling chute movement.

The representative sample will be prepared using an automatic system and thus will result the analysis sample.

CONCLUSIONS

It is thought that the sampling installation replies to the needs for which it was realised.

This device can be applied in all loading points where the material is supplied by means of high capacity belts.

The device fulfils the standardized requirements for the representative sample accomplishment.

The requisite number of the primary increments for the representative sample accomplishment can be determined for each case depending on the coal's specific feature in order to obtain the pursued accuracy.

REFERENCES

- N. Cristea et al.. – Mechanical sampling possibilities for the sub-bituminous coal in the loading points from Jilț Sud Quarry, Contract de cercetare C8/2001 Universitatea din Petroșani;
- N. Cristea G. Cristea. - Aspecte ale prelevării și prelucrării probelor în punctele de încărcare și livrare a lignitului către beneficiari, International Symposium Universitaria ROPET 2002 Petroșani
- *** STAS SR ISO 1988/1996

*Recommended for publication by Department of
Mine Mechanization, Faculty of Mining Electromechanics*