

MODERN SYSTEM FOR TESTING ELECTRICAL TRANSFORMERS

Cozma Vasile, Cercel Constantin, Grofu Florin

University "Constantin Brâncuși" of Tirgu Jiu, Romania

ABSTRACT: Electrical machines are basic components of any power system. Progress in leading industries is closely linked to developments in electrical machines, their performances respectively. In this paper proposes a monitoring system using modern electrical network analyzer CIRCUTOR CVM-BD-RED.

Keywords: electrical machines, data acquisition system, network analyzer

СЪВРЕМЕННА СИСТЕМА ЗА ТЕСТВАНЕ НА ЕЛЕКТРОТРАНСФОРМАТОРИ

Василе Козма¹, Константин Черчел², Флорин Грофу³

^{1,2,3} Университет „Константин Бранкуши“, Търгу Жиу, Румъния

РЕЗЮМЕ: Електрическото оборудване е основно при всяка енергийна система. Затова напредъкът при водещите промишлености е тясно свързан с електрическите машини и тяхното функциониране. В статията се предлага съвременна мониторингова система, използваващ анализатор на електрически мрежи CIRCUTOR CVM- BD – RED.

Introduction

Transformers and electrical machinery are some of the most important practical applications of electromagnetic phenomena. Electric cars are electromechanical equipment which convert mechanical energy into electrical energy or vice versa, as they operate under a power generator or electric motor.

The operating principle of electric machines based on two phenomena:

- a) the phenomenon of electromagnetic induction – that is induction of electric power in the conductors moving in stationary magnetic field continuously or in the fixed conductors in nonstationary magnetic field, with constant size;
- b) the phenomenon of developing electromagnetic forces due to interaction between magnetic field and covered conductors of electricity.

Rotating electrical machines have two armatures:

- a) inductor - is the system that creates electromagnetic induction magnetic field (excitation)
- b) induced - is the system that contains the winding (winding) which induce electric power.

In the operation of electrical machines, one of the two armatures, the stator, is fix and one moving part is called the rotor. Electrical machines can be built for DC or AC operation.

The electrical machinery group, ordinarily include transformers, the equipment as stationary electromagnetic electrical machines are not truly electrical machines and not transforms electrical energy into another form of energy but only change its parameters. Electromagnetic processes in

transformers based on the whole phenomenon of electromagnetic induction as electrical machines. This allows to study electrical transformer in common with AC electrical machines.

Transformers contain the following basic parts:

- a) two (or more) windings magnetically coupled - is a primary winding receiving electricity to be transformed and second (may be more than one), the secondary winding will produce electricity with transformed parameters;
- b) the magnetic circuit for creating strong magnetic coupling between windings.

Unlike electrical machines, electrical transformers have properties lacking parts relative motion between the conductor and magnetic field. That is why their operation is necessary to create variable magnetic field, that means electrical transformers work only AC.

Electrical machines and transformers are constructed and designed to work in given conditions, what determines their nominal operating regime. Nominal parameters characterizing this regime are called nominal. One of the basic nominal parameters for electrical transformers is rated apparent power which represents the secondary circuit terminals (S_{2n}) expressed as VA, kVA and MVA for not warming exceeded allowable limits of constituents in environmental conditions indicated (STAS -1703/2-80).

Electrical machines and transformers are the basic elements of any power system or electromechanical actuator systems. It is therefore necessary to know both theory and phenomena occurring in them during their operation.

Electrical transformers are static electromagnetic systems, which operate on the principle of electromagnetic induction, which converts AC power with some voltages and currents (u_1, I_1) in energy as with different values (u_2, i_2) with a constant frequency. They play an important role in generation, transmission and distribution of electricity.

For experimental determination of active power losses (in iron and copper for primary and secondary windings) in a transformer is running no load and short-circuit tests. These tests determine the parameters needed to determine the transformer equivalent scheme.

PFe losses, are the sum of losses from hysteresis phenomena p_H and swirl currents p_T ($p_{Fe} = p_H + p_T$), and is determined from no load tests.

PCU copper losses, are the sum of copper losses in copper primary winding and secondary winding p_{Cu1} p_{Cu2} , and are proportional to the square currents passing through the windings, and is determined from short circuit tests.

To determine experimentally the two forms of loss, it is necessary to fulfill the following conditions:

- a) transformer tests should not debit the consumer power (Fig. 1), that is the power absorbed by the primary winding, but must balance transformer losses;
- b) experimental installation is such that one of the two forms of loss to be low, so it can be ignored.

The proposed system

In any electronic measurement laboratory where there is at least an automated computer system IBM-compatible PC, you can perform a series of measurements, test operations and performance monitoring activities with the assistance of electronic computers, such as:

- measurement of specific parameters and sizes of electronic devices and circuits (electrical) under the term of storing and processing data from measurements and their representation in a convenient form for interpretation (graphs, tables, charts). This way you can measure quantities such as: terminal voltage, power, frequency, phase angle, phase, derive coupling factors etc. ;
- graphic representation, both on a 'display' proper procurement system and the "display" the computer, how to change the time or singular size dependence of different sizes of circuit parameters, frequency, temperature, etc.;
- monitoring the behavior of the operation of electrical equipment and installations, the operation of files (dedicated data)
- harmonic analysis (spectrum) signals for determining distortion (especially at high frequencies);
- representing the characteristics of signals and transfer functions of some floors in the form of frequency dependence (amplitude-frequency) or Laplacian.

The proposed system block diagram is shown in the figure 1.

Data acquisition system

The data acquisition system is achieved with network power analyzer CIRCUTOR CVM-BD-RED, shown in figure 2, which contain the current transducers for connecting to the three phase network supply.

The CVM-BD is an instrument which measures, calculates and displays all the main electrical parameters at any electrical network (balanced or not). The measuring is true RMS value, through three a.c. Voltage inputs and three a.c. Current inputs

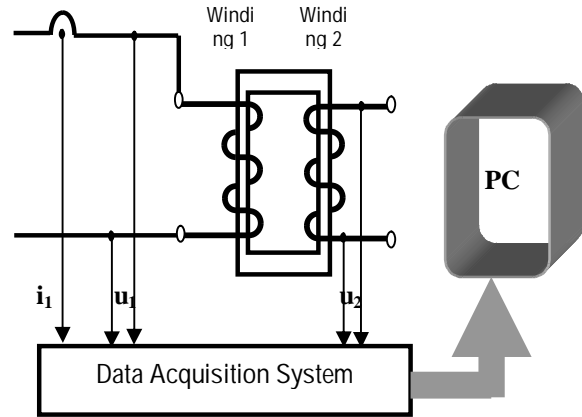

Fig. 1. Experimental scheme

(from Current Transformers .../ 5A).

The maximum values for the inputs are:

500V a.c. phase-neutral;

866V a.c. phase-phase;

5A current on phase, and for largest values must use current transducers.

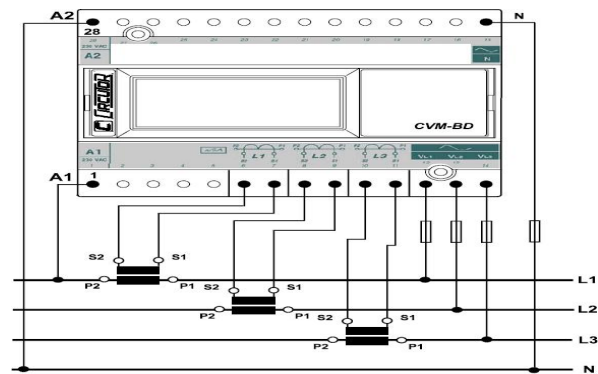

Fig. 2. CVM-BD-RED

In table 1 it is presented pinouts configuration for the device:

Table 1.

Terminal Nr	Designation	Concept
1 - 28	A1 - A2	supply voltage : 230 V a.c.
27 - 26	dep. model	Relay output N° 1 / 1 output of 4-20 mA
25 - 24	dep. model	Relay output N° 2 / 2 output of 4-20 mA
23 - 19	Termination resistor (RT)	240 resistor: adaptation of the line final impedance (bridge 23 - 22 and 19 - 20)
22	+	COM1 CVM-B : RS-485 connection to the PC 22 + -----> 1 (+) 21 GND -----> 5 converter 20 - -----> 2 (-) RS-485/RS-232
21	GND	
20	-	
16	-	COM2 : connection RS-485 to PERIPHERALS 16 - -----> (-) 17 GND -----> GND "network" 18 + -----> (+)
17	GND	
18	+	
15	N	NEUTRAL
14	VL3	Voltage phase 3
13	VL2	Voltage phase 2
12	VL1	Voltage phase 1
11 - 10	I L3: s1 - s2	Current phase L3 .../ 5 A
9 - 8	I L2: s1 - s2	Current phase L2 .../ 5 A
7 - 6	I L1: s1 - s2	Current phase L1 .../ 5 A

Analyzer CVM-BD-RED has built an RS-485 communication interface through which the device can send all the parameters measured and calculated to a central processing unit (PC). Also, this device can be connected to an RS-485 communication network, making access to the address on each device. Figure 3 illustrates how to connect a RS-485 communications network for data transfer and adaptation of the PC. Communication with PC is done through the serial port and using a converter to adapt the RS-232 / RS-485.

Software to connect to data acquisition system is developed in LabWindows/CVI development environment. LabWindows/CVI is a programming environment integrated American National Standards Institute (ANSI) C developed by the company National Instruments and is designed for engineers and researchers to create applications with virtual instruments. LabWindows / CVI software is useful for developing flexible and inexpensive measure using traditional measurement methods. Software LabWindows/CVI is primarily used in automated test systems, project monitoring and data acquisition, measurement and verification testing, process monitoring and control.

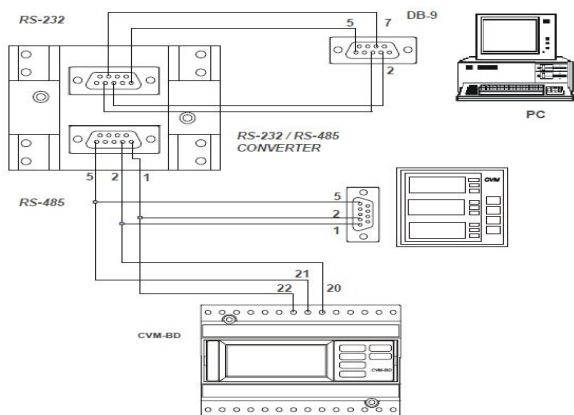

Fig.3 Connecting CVM-BD-RED

Results

To test and validate the proposed system was done through a software application that can view graphics the evolution of

Recommended for publication of Editorial board

the monitored and recorded parameters and calculated data in tabular form. The application also provide the opportunity to view certain parameters (voltage, current, power factor, etc.) regardless of the display of graphs and tables.

Graphical user interface application is shown in figure 4

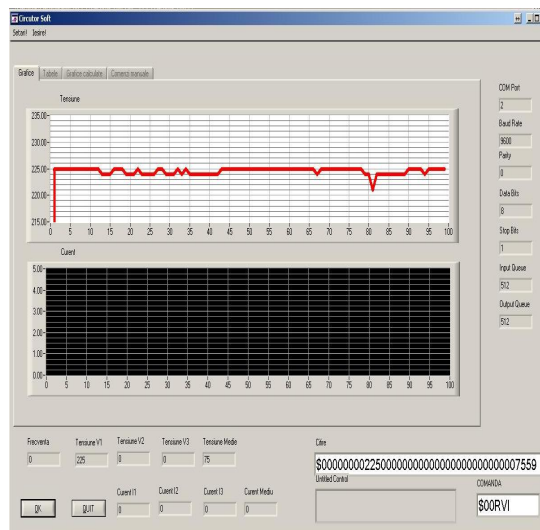

Fig. 4. Graphical user

References

Milev I., Electrotehnica i Electronica , Sofia 1992
 Cozma V. ș.a., Electrotehnică și mașini electrice, Editura SITECH, Craiova, 2008, ISBN 978-973-746-862-8
 Cozma V. ș.a., Aparate si masini electrice, Editura SITECH, Craiova, 2007, I.S.B.N. 978-973-746-690-8
 Cozma V. ș.a., Transformatorul Electric-Teorie și aplicații. Editua SITECH, Craiova, 2005, I.S.B.N. 973-657-882-8;
 Cercel C., Grofu F., „USB to Parallel communication interface”, Annals of „Constantin Brancusi” University of Tirgu Jiu, The XIII-th edition of the international scientific conference of the Engineering Faculty, November 07-08, 2008, pag. 269-276, ISSN 1844-4856
 CIRCUTOR CVM-BD-RED – INSTRUCTION MANUAL