

APPLICATIONS OF STEPPING MOTORS IN MINING APPLIANCES

Onisifor Olaru

"Constantin Brâncuși" University
Str. Geneva, nr. 3
Târgu Jiu, 1400
Romania

Luminița Popescu

"Constantin Brâncuși" University
Str. Geneva, nr. 3
Târgu Jiu, 1400
Romania

Gabriel Gîdei

"Constantin Brâncuși" University
Str. Geneva, nr. 3
Târgu Jiu, 1400
Romania

ABSTRACT

The development of the hardware command structures of the stepping motors and the compatibility of these motors with the numerical technique have opened new perspectives to the control systems with stepping motors, from the point of view of appliance domains, but also from the point of view of the achieved performances. In the following article is presented the control of the ventilator's flow capacity using a stepping motor.

CONTROLLING THE VENTILATOR'S FLOW CAPACITY

For the mining's main aeration, according with the flux capacity and with the pressure, it can choose axial or radial ventilators. Theirs action can be aspiring or refulant, and according with the necessities, some of them have the possibility to change the way of working.

To control the radial ventilators flow capacity at modern ventilators stations is used a ring-shaped device with vertical window blinds. This device is mounted at the aspiring plug of the ventilator and his driving can be realized with a stepping motor or with an electro-hydraulic stepping motor.

The principle scheme of the ring-shaped device driving with vertical window blinds with electro-hydraulic stepping motor is shown in figure 1. The stepping motor modifies the angular position of the vertical window blinds thru the medium of a mechanical system composed from: cam – lever – lighting – control cable.

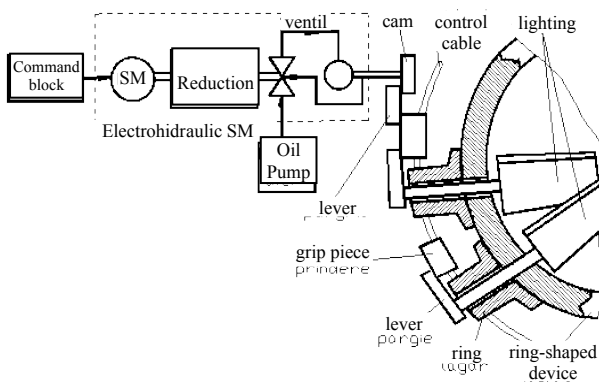

Figure 1.

Axial ventilators presents, comparing with the radial ones, numerous advantages [1].

One of these is referring to the way in which is realized the flow capacity and the pressure. This tuning is made by modifying the position angle of the pales, in the hypothesis that this angle's values are found in the execution limits of the ventilator. In the case of the axial ventilators the values necessary for the flow capacity and for pressure consists the functioning static point coordinates of the ventilator.

Automatic guidance of the aeration process [2] imposes the modification of the palette's position angle, α , in the purpose of realizing the static point of functioning of the ventilator.

In the context of calculating the aeration, for establishing the coordinates of the ventilator's static point of functioning, there are necessary it's technical characteristics. They show the dependence of the pressure H from the flow capacity, for a certain value of the α angle and are given by the relation:

$$H = f(Q)|_{\alpha = \text{const}} \quad (1)$$

These characteristics don't allow the determination of the tuned parameter α , of the ventilator, corresponding to the static point of functioning obtained by calculating the aeration, parameter necessary to establish the reference value of the ventilator's aeration system.

In consequence, it's imposed to determine the equations of the static characteristics family of the following form:

$$H = f(Q, \alpha) \quad (2)$$

The explicit form of the static characteristics [2] is given by the relation:

$$H = A(\alpha)Q^2 + B(\alpha)Q + C(\alpha) \quad (3)$$

where the coefficients A , B , C are square functions that depend of α .

For a axial ventilator with the controllable α angle (in the domain $15^\circ - 45^\circ$) were obtained [2] the following expressions for the coefficients A, B, C:

$$\begin{aligned} A(a) &= 0,00033a^2 + 0,0137a - 0,09 \\ B(a) &= - 0,059a^2 + 3,415a - 30,91 \\ C(a) &= 1,628a^2 + 95,02a + 291,51 \end{aligned} \quad (4)$$

Knowing the A, B, C coefficients and the equation [3] can be determined the α angle, for a given static point. Between the two resulted values for α is chosen the one that is in the interior of the interval, the one for which the reported error at the static point is minimum.

The automatic guidance of the aeration process considers knowing the transfer function that characterizes the dynamic régime behavior of the ventilator.

Considering the axial ventilator as oriented object, having as output value the flow capacity Q and as input value the α angle, his transfer function $H_V(s)$ is defined as being:

$$H_V(s) = \frac{Q(s)}{\alpha(s)} \quad (5)$$

The block scheme of the ventilator, corresponding to this transfer function, is given in figure 2:

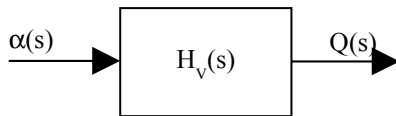

Figure 2.

For an axial ventilator, corresponding to the representation from figure 2, it was established [2] the following expression for the transfer function:

$$H_V(s) = K_V(\alpha) \quad (6)$$

The expression of the transfer function [6] leads to adopting an adaptive tuning system for the ventilation system, where modifying the slope angle of the palettes controls the flow capacity.

Changing the position angle of the palettes can be realized with a electro-hydraulic stepping motor 4, figure 3, with mounted gearing on the ventilator's hub, rotating with the ventilator. Engaging the palettes 1, to modify the position angle, is realized thru a conical transmission and a device with endless screw 3, which is functioning with a palettes command ring 2, which, thru a system of small balls with belt, is realizing the rotation of the palettes axles. Piece 5 is an equilibration table.

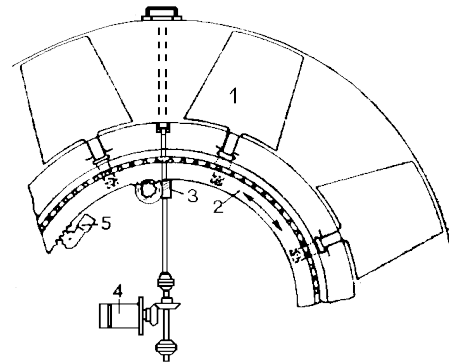

Figure 3.

The command block of the motor is realized according with [3].

CONCLUSIONS

Stepping motor is used with good results in applications in witch the torque is constant. The advantage of that is the use of simple command schemes witch don not use reaction loops for position control.

REFERENCES

- Popa A., - Engineering Mining Manual, vol. V, Ed. Tehnică, București, 1989.
- Poantă A., Contributions on mining ventilation process control, Petroșani University, 1990
- Kenjo Takashi., Stepping Motors and their Microprocessor Controls, Oxford University, Press, 1985